

LANTERN BAY

Approved Locking Mailbox



mailboss.com

Available from Amazon & Home Depot

Mail Boss Mail Manager

The Mail Manager by Mail Boss is a USPS-approved locking mailbox for residential use that protects against theft and vandalism. It accepts mail bundles and small packages, features anti-fishing design, heavy-gauge galvanized steel construction, an anti-pry latch, and a high-security lock with laser-cut keys.

Product Specifications

Dimensions: 10.75"W x 11.25"H x 21"D

Weight: 22 lbs

Model: 7506

Color: Black



MAILBOX POST INSTALLATIONS FOR LANTERN BAY HOA

TO BE USED FOR SOLAR LOCKING MAILBOXES

SINGLE BOX CONFIGURATION

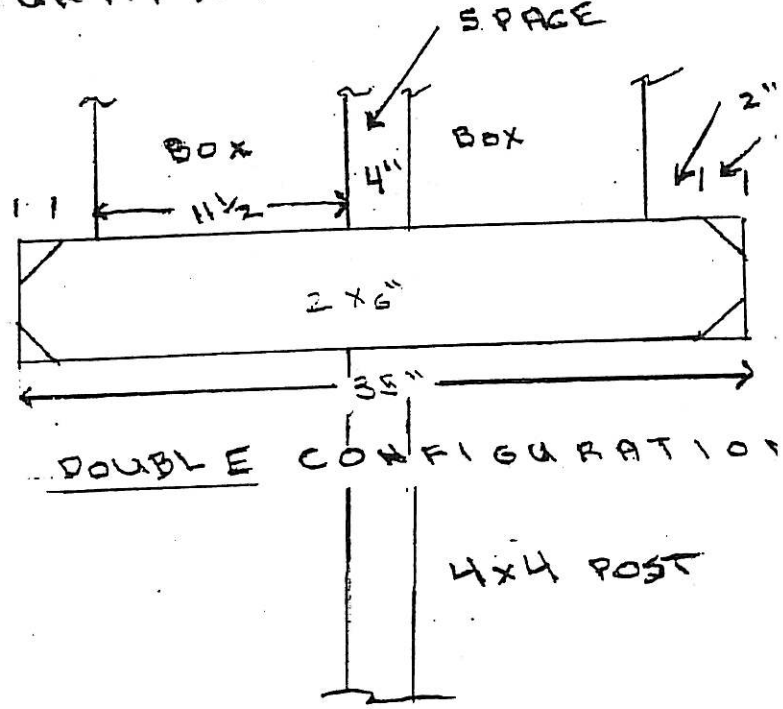
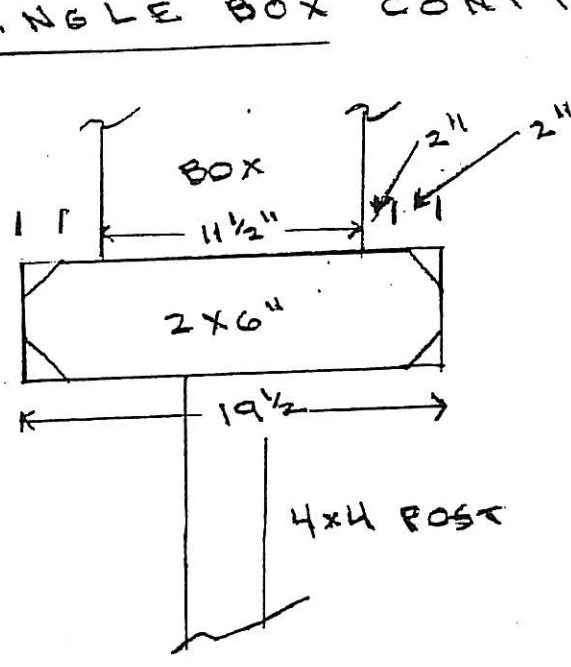

TRIPLE CONFIGURATION

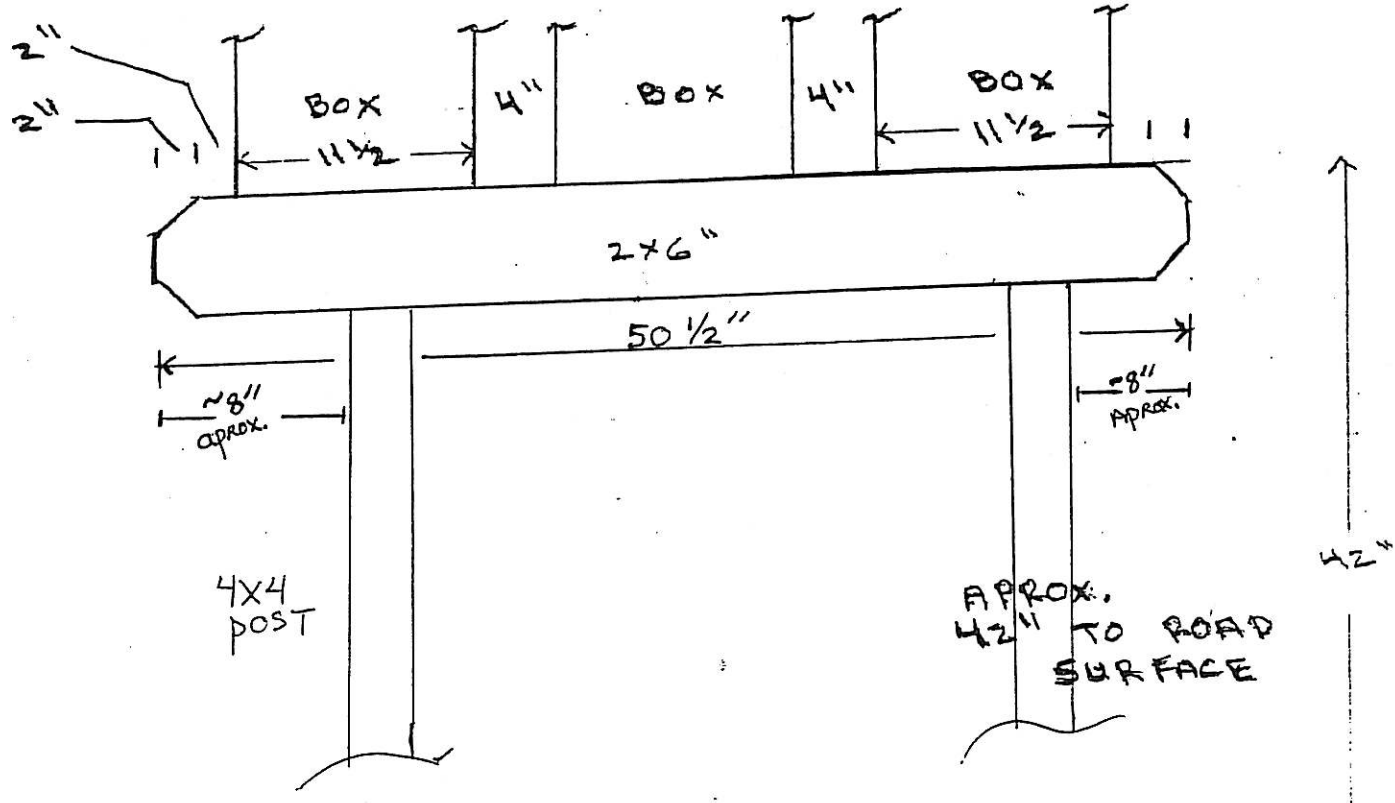

LANTERN BAY

4 BOX 2 POST INSTALLATION

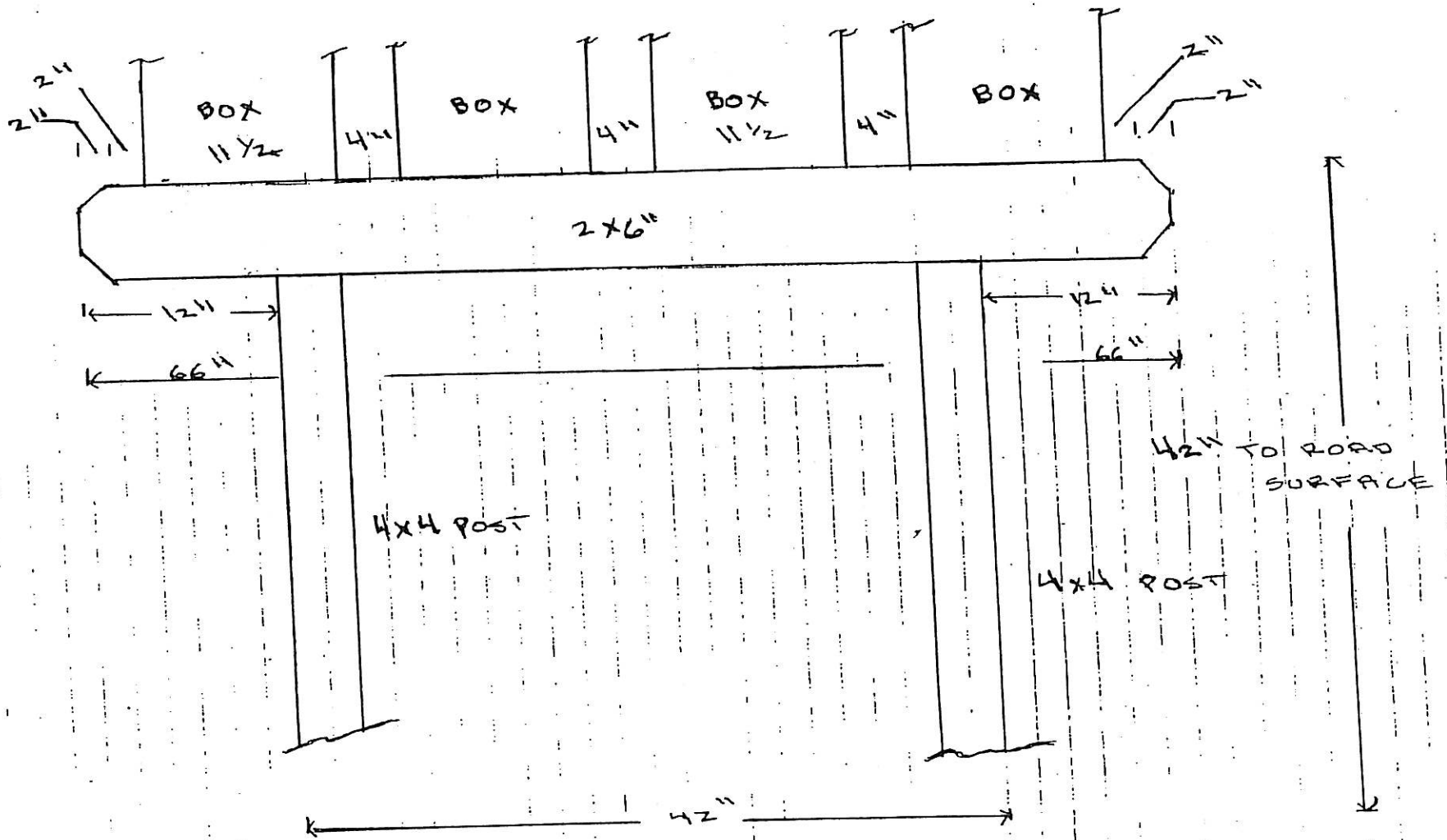

LANTERN BAY

POSTS - 4"x4" REDWOOD, PRESSURE TREATED OR "EXROTENTIAL"

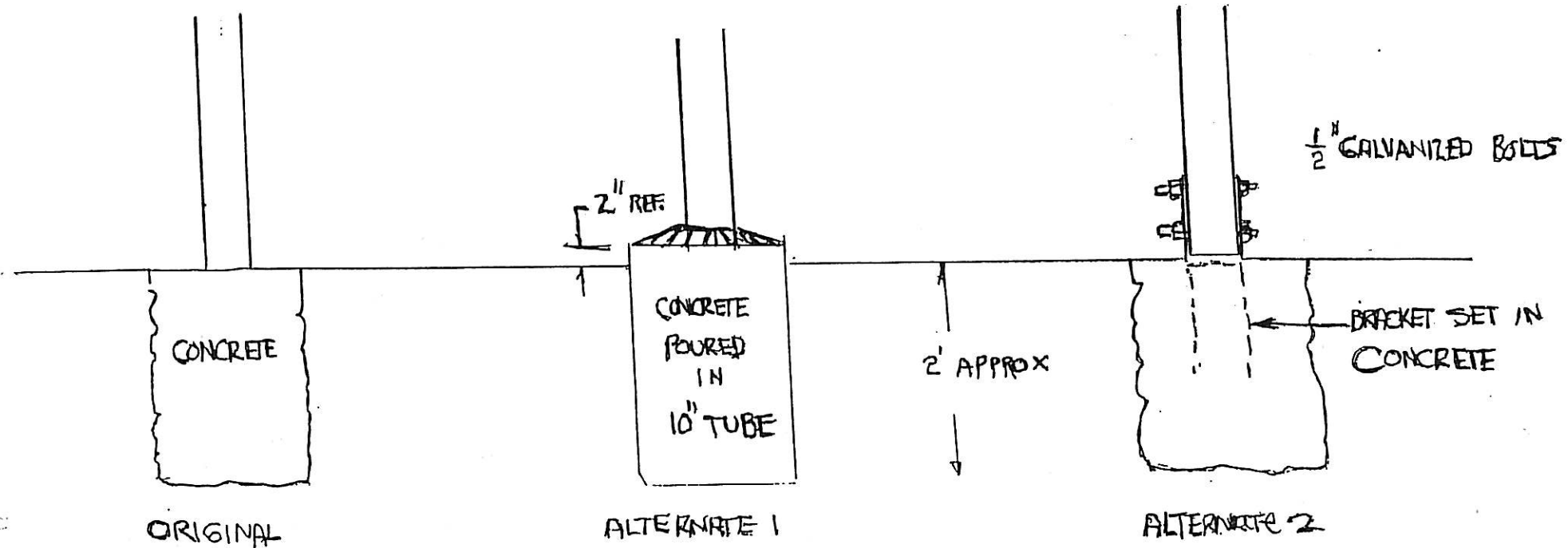

LANTERN BAY