

# BAYVIEW HARBOR

## Approved Locking Mailbox



mailboss.com

Available from Amazon & Home Depot

### Mail Boss Mail Manager

The Mail Manager by Mail Boss is a USPS-approved locking mailbox for residential use that protects against theft and vandalism. It accepts mail bundles and small packages, features anti-fishing design, heavy-gauge galvanized steel construction, an anti-pry latch, and a high-security lock with laser-cut keys.

### Product Specifications

Dimensions: 10.75"W x 11.25"H x 21"D

Weight: 22 lbs

Model: 7506

Color: Black



BAYVIEW HARBOR

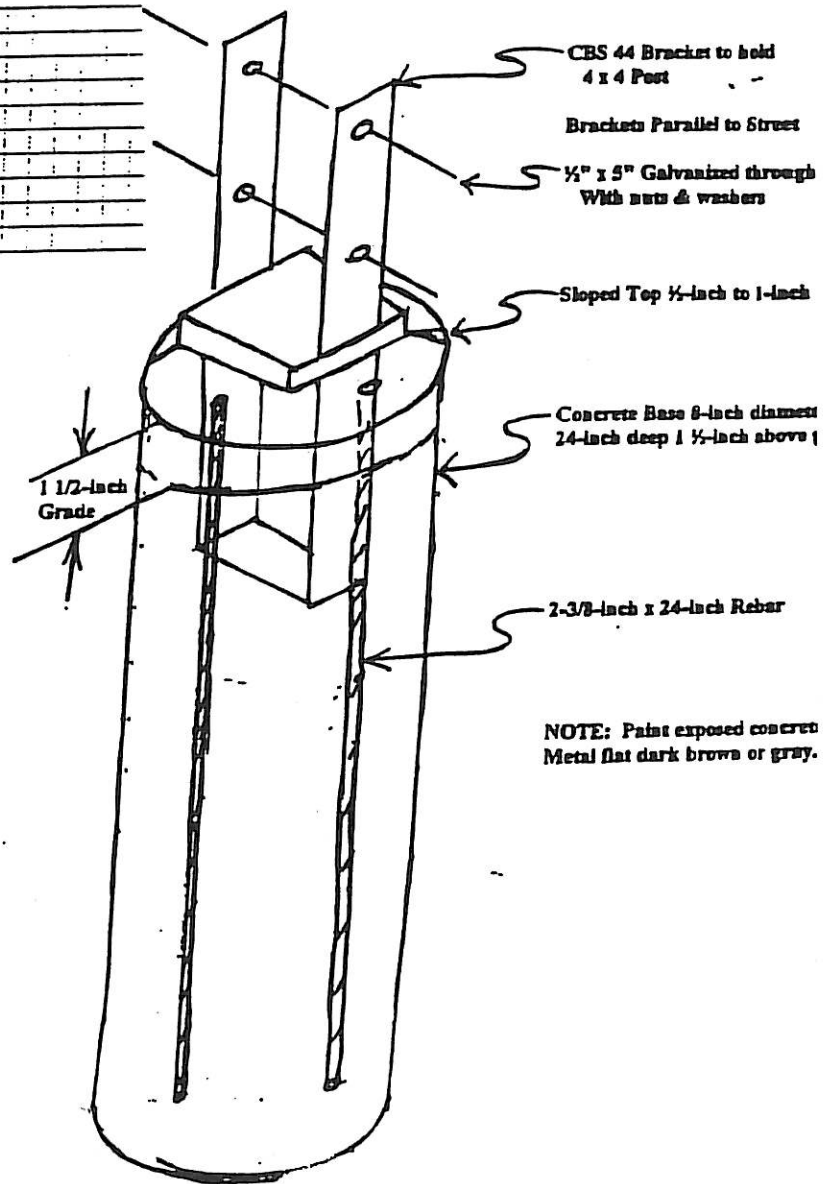
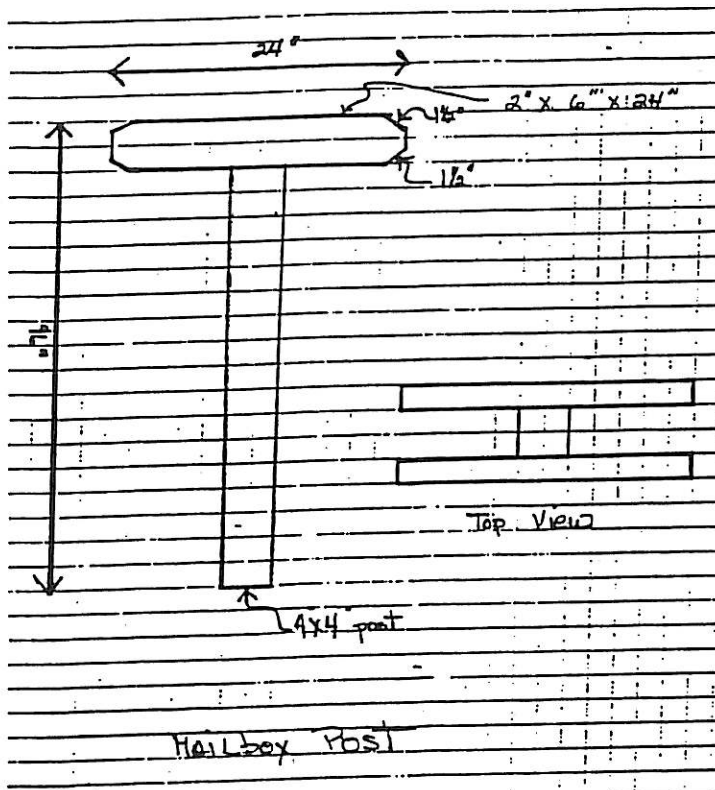

NOTE: Paint exposed concrete Metal flat dark brown or gray.

RESOLUTION: # 99-02

DATE: October 12, 1999

**RESOLUTION  
OF THE BOARD OF DIRECTORS  
BAYVIEW HARBOR HOME HOMEOWNERS' ASSOCIATION  
"MAILBOX REPLACEMENT &  
MAILBOX POST INSTALLATION POLICY"**

**WHEREAS**, the Board of Directors for the Bayview Harbor Homes Homeowners' Association is committed to maintaining property value and a common code of conduct and order throughout the Association; and

**WHEREAS**, a common code of conduct and order requires establishing and distributing rule, regulations and guidelines; and

**WHEREAS**, the Association's Covenants, Conditions and Restrictions empower the Board of Directors to adopt Rules, Regulations and Guidelines for the orderly governance and good of all members; and

**THEREFORE, LET IT BE RESOLVED**, that any homeowner at Bayview Harbor Homes that intends to replace their mailbox post, must comply with the following requirements:

1. Mailboxes are to be black in color and standard rural post office certified.
2. If house numbers are placed on the mailbox, the number shall be one (1) inch in height and white reflective and placed on the door of the mailbox.
3. The mailbox post must be redwood lumber.
4. The mailbox posts are to be installed per the dimensions shown on the attached drawings.
5. The mailbox post must remain natural or a clear wood preservative can be applied.
6. Cement pads are to follow the directions shown on the attached drawing.
7. Brackets are to be placed parallel to the street.
8. Homeowners are responsible for all engineering necessary to ensure structural and functional integrity.

This Resolution is adopted and made part of the minutes of the membership meeting on October 12, 1999.

[OVER]