

BAY ISLE POINTE

HOMEOWNERS ASSOCIATION

ARCHITECTURAL GUIDELINES

2010

2010

**BAY ISLE POINTE HOMEOWNERS ASSOCIATION
ARCHITECTURAL GUIDELINES
2010**

TABLE OF CONTENTS

CC&R COMPLIANCE.....	1
COMMUNITY ARCHITECTURAL REVIEW & LANDSCAPE STANDARDS GUIDELINES.....	1
ARCHITECTURAL MODIFICATIONS AND PROPERTY IMPROVEMENTS.....	1-2
BUILDING MODIFICATIONS.....	2-10
Address Numbers.....	2
Air Conditioners.....	2
Antennas/Satellite Dishes.....	2
Attic Ventilation.....	2
Awnings, Exterior Shades/Sun Shields.....	2
Basketball Standards.....	3
Chimneys, Stove Pipes and Metal Flues.....	3
Entry Door.....	3
Garages.....	3
Garage Doors.....	3
Gutters and Downspouts.....	3-4
Lights – Outdoor.....	4
Paint.....	4-6
Porches.....	6
Roofs.....	6-7
Roof Metals.....	7
Room Additions/Extensions.....	8
Ground Level Additions.....	8
Second Story Additions and Balconies.....	8
Third Story Room Additions.....	8
Security System.....	8
Siding/Trim.....	8
Skylights.....	8
Solar Collectors.....	8
Solariums.....	9
Utility Boxes.....	9
Windows.....	9
Wires, Lines or Conduit.....	10

TABLE OF CONTENTS - CONTINUED

OUTDOOR YARD STRUCTURES.....	10-15
Animal Shelters.....	10
Arbors, Gazebos & Overhead Trellises.....	10
Barbecues or Fire Pits.....	11
Benches.....	11
Clothes Drying Facilities.....	11
Decks.....	11
Docks.....	11-12
Driveways & Interlocking Pavers.....	12
Fences.....	12
Fence/Gate Replacement.....	12
Fence Extensions.....	12-13
Firewood.....	13
Flagpoles and Flags.....	13
Furniture.....	13
Garbage and Recycling Containers.....	13
Insect Traps.....	13
Lights.....	13
Light Fixtures.....	13
Mail Boxes.....	14
Mail Box Posts.....	14
Patios.....	14
Sheds.....	14
Signs.....	14
Spas & Saunas.....	14-15
Speaker System.....	15
Sports Apparatus.....	15
Trellises.....	15
Vehicle Storage.....	15
Walkways.....	15
Weather Vanes.....	15
Wind Chimes.....	15
Wrought Iron Fences.....	15

TABLE OF CONTENTS - CONTINUED

LANDSCAPE GUIDELINES..... 16-17
Prior Approval Required..... 16
Bark-Mulch..... 16
Drainage..... 16
Drought-Resistant Landscape..... 16
Groundcover..... 16
Hardscape..... 16
Lighting..... 17
Maintenance..... 17
Planter Boxes or Flower Pots..... 17
Rock Gardens..... 17
Trees Installation..... 17
Vegetable Gardens..... 17

EXHIBITS

- Exhibit “A” – Roof Rake Installation Method
- Exhibit “B” – Proper Window Replacement Installation Details
- Exhibit “C” - Mailbox Post Construction Detail Sheet
- Exhibit “D” – Maximum Building Envelope for Lagoon Decks and Patios
- Exhibit “E” – House Painting Detail Diagram
- Exhibit “F” – Fence Extension Detail Sheet
- Exhibit “G” – Approved Gutter Profiles

INDEX

BAY ISLE POINTE HOMEOWNERS' ASSOCIATION ARCHITECTURAL AND LANDSCAPE GUIDELINES

The Guidelines were developed to maintain Bay Isle Pointe's harmonious design and to preserve the property values of all homes. The Bay Isle Pointe Homeowners' Association consists of two project developments: Bay Isle Pointe and Victoria Bay. Consequently, the Guidelines may differ somewhat between the two projects regarding exterior details, etc.

CC&R COMPLIANCE

When you purchased your home, you took title to your Lot subject to all restrictions, easements, etc. recorded on your Lot as set forth in your Policy of Title Insurance. You also took title to your Lot subject to all of the provisions set forth in the CC&Rs recorded on your property as set forth by the Community of Harbor Bay Isle Owners Association (Community) and the Bay Isle Pointe Homeowner's Association (Association).

While your Architectural Committee reviews applications to see if the plans conform to the Architectural Guidelines, it is the Bay Isle Pointe Homeowner's Association, through its Board of Directors, which enforces the Covenants, Conditions and Restrictions (CC&Rs) to control the appearance of its neighborhoods.

COMMUNITY ARCHITECTURAL REVIEW AND LANDSCAPE STANDARDS GUIDELINES

Owners should review the Community's Architectural Rules for specific requirements that apply to proposed property improvements. The Community Architectural Rules have been adopted by the Bay Isle Pointe Homeowners' Association. Where certain provisions and requirements are not addressed in the Bay Isle Pointe Association Rules, the Community Architectural Rules shall prevail. The Association has created these more specific Guidelines for use by Bay Isle Pointe homeowners. In addition, the Bay Isle Pointe Homeowners' Association Architectural and Landscaping Guidelines may be more restrictive and shall prevail over the Community Architectural Review and Landscape Standards Guidelines.

ARCHITECTURAL MODIFICATIONS AND PROPERTY IMPROVEMENTS

The Association and Community CC&Rs require that **no** additions to homes or property are allowed, nor may any alterations or improvements of any kind be made on the property until approved in writing by the Architectural Committee or Board of Directors.

Homeowners should complete Architectural application and plans, submit them to the Community offices and receive approval in writing before beginning any work. Architectural applications are available at the community offices of Harbor Bay Isle and online at www.harborbay.org. The application process may take 2 to 4 weeks for review and approval so please allow sufficient time for review before scheduling any work. The Community Architectural Committee's meeting schedule is on the back page of the application. The Architectural Administrator is available to help you complete the application and plan the review process as quickly as possible.

Property improvements include **all** improvements/repairs to the exterior surfaces of the house, including repainting, **any** building modifications, and **all** improvements to the land, including landscape, hardscape, or **any** structural additions to the land.

BUILDING MODIFICATIONS

All proposed building modifications require the submission and approval of an architectural application and plans **prior** to the commencement of property improvement work.

Address Numbers Polished brass, antique brass and cured wood painted trim or white color of the same size as original wood numbers. Brown, dark green or black plates behind numbers are allowed. Numbers must be attached to the house except in cases where the numbers would not be visible from the street if attached to house. In these instances numbers, on a plain plate, may be staked. Ceramic tile, plastic numbers are not allowed. Light boxes, originally installed, are allowed ONLY in Victoria Bay.

Air Conditioners are permitted only in rear, non-window locations and must be concealed from a neighboring property. The sound level shall not unreasonably intrude into the neighboring property. Window air conditioning units are not permitted.

Antennas/Satellite Dishes must comply with the Community of Harbor Bay Isle Owners Association Architectural Rules & Standards. Owners are encouraged to install Antennas and Satellite Dishes in an area that is not visible from a public way (i.e. not visible from streets, sidewalks, parks, lagoon paths, etc.) A final inspection is required after the installation.

Attic Ventilation devices shall be compatible in design and color to the existing structure. Turbines are not permitted.

Awnings, Exterior Shades/Sunshields are not permitted.

Basketball Standards are not permitted to be attached to any structure. Portable basketball standards are permitted for use in accordance with the Community of Harbor Bay Isle Owners Association Architectural Rules & Standards.

“Temporary basketball standards shall be”

1. free standing from any residential building, fence or other permanent structure;
2. temporary in their use and location;
3. stored out of view from public ways or neighboring properties;
4. used only during daylight hours;
5. used only in driveways, auto courts, or on the auto side of the house; except standards no higher than five feet may be used in back yards;
6. used without any additional artificial lights;
7. used so as not to create a nuisance of any neighbor or other resident.”

Chimneys, Stove Pipes and Metal Flues must be compatible in material and color with the existing structure. If interior stoves are installed, the stove pipe protruding above the roof must be painted to match the other roof pipe and vent colors. Any exterior portion of the stove pipe that does not protrude through the roof must be boxed in with material matching the house and painted to match the house siding color.

Entry Door design, material (wood) and size, must match the original installed door or alternate design, material or size approved by the Architectural Committee on a case-by-case basis. Fiberglass and metal doors may be approved if they are of a similar design to the original doors with raised panels, and are painted. All doors may be painted the siding, trim or the approved accent color. Wood doors may also be stained using one of the approved Minwax Gel Stain colors (#601 through #608). Front entrance screen doors or storm doors are not permitted.

Garages shall not be remodeled or used for purposes that will interfere with the accommodation of family vehicles. Owners are urged to keep their garage doors closed except when entering or exiting the garage to maintain the attractive appearance of the neighborhood and to reduce the possibility of unlawful entry and theft.

Garage Doors must match the original installed door in design and size or may be replaced with sectional, wood-grain metal doors. Replacement doors **must be painted** with the same paint as the trim or siding to **exactly** match the siding or trim color and sheen. Two color garage doors are not permitted. Windows are not permitted in garage doors.

Gutters and Downspouts Replacement gutters and downspouts may be constructed of aluminum or galvanized steel. Gutters must be of equal size and

resemble the curved fascia shape originally installed with one, two, or three horizontal reinforcement ribs unless otherwise approved by the Architectural Committee. Gutters must be painted using the same paint as the trim paint to exactly match the trim (or fascia paint if a third accent color is used). Downspouts must be painted using the same paint as the house surface against which they rest to exactly match (siding, trim, or fascia paint), regardless of whether unpainted galvanized or factory painted aluminum is used. In areas where downspouts pass in front of bricks, the color shall remain that of the house siding.

Please see Exhibit G for approved gutter profiles.

Drainage shall not adversely impact the adjacent properties. Refer to the attached House Painting Guideline for more specific designations applying to gutters and downspouts.

Lights – Outdoor shall be the same style as originally installed fixtures – brass, antique brass or black (or alternate style and/or finish approved by the Architectural Committee on a case-by-case basis).

Unshielded spotlights or flashing lights are prohibited. Security lights must be shielded and used for emergencies only. Motion detectors are permitted provided the lights are shielded from public view and do not create an annoyance. Lights, or their effect, shall not intrude into neighboring properties. No colored bulbs are allowed in light fixtures, including landscape lighting, with the exception of holiday season lights during the time specified for seasonal lights.

Light installations on docks are prohibited.

Seasonal lights are allowed only during the holiday season. They may be installed each year after November 20th and must be removed by January 31st. Cascading white or colored mini-bulbs and rope lights are considered seasonal lights and are governed by this rule.

Paint, Exterior

Exterior color schemes for homes in Bay Isle Pointe shall maintain the visual character and harmony of the neighborhood. Before painting is begun, an Architectural Application for repainting must be filed by the homeowner with the Community of Harbor Bay Isle (CBHI). Applications are reviewed by the Bay Isle Pointe Project Architectural Committee (BIPPAC), and must be approved by the Community of Harbor Bay Isle Architectural Committee prior to start of any work.

Bay Isle Pointe's new exterior paint palette is based on Kelly Moore stock brand paints. The selected color scheme must be different from the immediate neighboring houses on all adjacent properties. Substitution of colors within an individual scheme is not allowed. The developer paint color schemes have been discontinued and may no longer be used.

All of the available color schemes are included in the Paint Book including color samples. Homeowners may choose from any of these approved color schemes, except as noted. Color Paint Books are on file with CHBI and may be viewed at the CHBI office during regular business hours. The color palettes are based upon a single manufacturer's available paint selections for homeowner convenience. Homeowner's may purchase from this manufacturer or may have the approved colors matched by another paint manufacturer. All color matching must match the approved paint colors.

Bay Isle Pointe prefers that homeowner's select from the approved color palettes. A homeowner may propose an alternate color scheme, using colors from Kelly Moore or another manufacturer, with their Architectural Application. Alternate color schemes are subject to review and approval by the Community of Harbor Bay Isle Architectural Committee and the Bay Isle Pointe Board of Directors. If a homeowner chooses this option, they must provide three (3) paint chips of each color with their Architectural Application.

The color schemes are specific to siding, trim, fascias and accents. Siding colors may only be used for siding; trim colors only for trim; fascia colors only for fascias and gutters; and accents as noted with the color scheme.

Garage doors may be painted to match the siding or trim colors. The garage door must be painted one (1) color only.

All vents, gutters, downspouts, diverters, meter boxes and utility devices, doors or enclosures shall be painted to match the color to which they are attached.

All exposed metal flashing must be painted with the same paint color as the trim and fascia color. All exposed metal flues, roof jacks, skylight frames, vent pipes and other similar items shall be painted to match the color of the roof.

Front entry doors are preferred to be stained wood and may be finished to match transparent stain finish, Minwax Gel Stains Nos. 601 – 608. Front doors may also be painted to match the siding, trim or, on a case by case basis, the approved accent color for your color scheme. Front entry doors shall be painted or stained one (1) color only.

French doors (including sliding French Doors) are to be stained one of the approved Minwax Gel Stain Colors (#601 - #608) or painted with the same paint and color as the siding or trim color.

Any color scheme must be applied in accordance with the above guidelines and the Harbor Bay Isle "Rules and Standards."

No changes permitted after the color scheme has been approved unless such changes are resubmitted and approved.

Paint Gloss Categories

<u>FLAT</u>	<u>LOW SHEEN</u>	<u>SATIN</u>	<u>EGGSHELL</u>
Siding	Siding	Siding	Trim
	Trim	Trim	Accent
	Accent		

Semi-gloss and gloss paint categories may not be used.

SUGGESTIONS FOR PAINT PREPARATION AND REPAINTING THE EXTERIOR OF YOUR HOME

1. Power-wash house exterior to remove loose paint and dirt
2. Caulk and prepare exterior
3. The primer paint should be oil-based. Ask your painter for advice
4. Pipes, sheet metal vents and other miscellaneous metal elements on the roof shall be painted with a rust-retardant undercoat with a final paint coat in a color to match the roof color.
5. Owners are required to paint the raw metal of the security alarm boxes (leaving only the decal area unpainted) to match the surface to which it is attached.

PLEASE REFER TO EXHIBIT “E” – HOUSE PAINTING DETAIL

Painting of Wrought Iron Fences/Handrails The wrought iron fences along the Lagoon path and on Lagoon lots are to be painted with ***Pittsburgh Paints Pitt-Tech DTM 90-444 Satin Bronze Tone***, or equivalent. The iron handrail at the entry of some home models shall be painted to match the original coating color.

Porches must be compatible in design, material and color with the existing structures and not extend beyond existing roof overhang. Screened in porches are not permitted.

For purposes of distinction herein the definition for porches is a covered entrance to a building, including extensions thereof that are not covered.

Roofs shall be maintained in good condition. The City of Alameda Roofing Ordinance #275 requires that replacement roofing be Class A fire resistant roof system including chimney and stove pipe spark arrestor of not greater than ½ inch mesh.

Homeowners who wish to re-roof their homes must comply with the following requirements:

1. **APPLICATION** Before replacement begins, an Architectural Application for re-roofing must be filed by the homeowner with the Community of Harbor Bay Isle (CBHI). Applications are reviewed by the Bay Isle Pointe Project Architectural Committee (BIPPAC), and must be approved by the Community of Harbor Bay Isle Architectural Committee prior to start of any work. The homeowner must have an approved “Architectural Application” from the Community and Bay Isle Pointe Architectural Committee prior to demolition or installation of any new roofing material. All applications for re-roofing must state whether or not the gutters and/or downspouts will be replaced with the re-roofing work. The homeowner must obtain a building permit for re-roofing from the City of Alameda prior to the start of any re-roofing work.
2. **MATERIALS** The new roofing materials to be installed must be one of the following:
 - a. **CEDAR WOOD SHAKES** Chemco FTX treated Meeker Cedar Shakes; Heavy (3/4 inch) or Clarke Group Cedar Plus/Chemco Inc. Heavy (3/4 inch)
 - b. **ASPHALT-FIBERGLASS SHINGLES**
 - 1) Landmark TL in Country Grey color
 - 2) GAF – Elk Timberline Prestique High Definition Roofing Shingle, 40 year warrantee, asphalt roofing in Weathered Wood color.
3. **ROOF METALS** All roof metals (flashing, diverters, vents, pipes, flues, etc.) must be painted to match the roof color. Roof-edge “nosing edge flashings”, if any, shall be painted to match the adjacent trim or gutter-fascia color as required in the exterior house painting guidelines.
4. **GUTTERS** Gutters must be of equal size as the original and must resemble the curved or straight fascia shapes of the original. (See Exhibit G) Straight fascias with one, two or three horizontal reinforcement ribs must match the original gutters unless otherwise approved by the Architectural Committee. Gutters must be painted to exactly match the color of the trim (or fascia if a third color is used). Downspouts must be painted to exactly match the color of the house surface against which they rest (siding, trim or fascia), Gutters and downspouts must match the house paint colors as noted above, regardless of whether unpainted galvanized or pre-painted aluminum.
5. **SIGNS-CONTRACTOR SIGNS** Homeowners’ contractor signs are not permitted on private property or on Association Common areas.

Important Note

GAF – Elk Timberline “Natural Shadow Roofing Shingle” may NOT be used.

Homeowners are responsible for their contractors' compliance with this rule.
Refer to Community House Rule HR-1 for all other sign compliance.

IMPORTANT Refer to the **Roof Rake Installation Method guideline sheet attached hereto as Exhibit "A"** for acceptable installation detail and also refer to the paint guidelines above for rules concerning painting of the metal flashing at the shingle mould and painting of roof penetrations)

These roofing materials were selected to retain the shake-like appearance of the roofs. Each property owner is individually responsible for ascertaining from a professional that his structure will support the weight of the roof assembly.

Room Additions/Extensions All new room additions or extensions impacting the exterior of existing dwellings shall be constructed of wood frame construction to match the existing construction and to be harmonious with the architectural character of the existing dwelling. Exterior finish materials, colors and details, such as siding, door and window sash, roof eave, and architectural trim details of the proposed addition must match those of the existing dwelling.

Room additions/extensions at ground level Proposed room additions will be considered by evaluating the impact on the remaining lot open space ratio as well as the Lagoon Lot Building Envelope requirements if the lot is a lagoon lot on a case by case basis.

Second story room additions/extensions including balconies Second story room additions/extensions will be considered by evaluating the impact on the overall appearance of the neighborhood and the retention of the neighboring property privacy on a case by case basis,

Third story room additions Third story room additions are prohibited.

Security System should be as unobtrusive as possible taking into consideration their purpose. Security lights must be shielded and used for emergencies only. Motion detectors are permitted provided the lights are shielded from public view and their operation does not create an annoyance.

Siding/Trim replacement materials must match the original installation. Siding manufactured from metal, fiberglass or vinyl is prohibited.

Skylights are permitted provided they are compatible with the existing structure and do not unduly impact on the home's appearance that is visible from the street, or other public ways such as sidewalks and paths. Solar tube skylights will be considered on a case by case basis depending on size, number, and visibility from public ways.

Solar Collectors are permitted if compatible with the house and roof design and are properly concealed from public ways. Solar collectors are permitted under

California Civil Code 714. The Civil Code allows for “reasonable restrictions”. Solar collectors must be installed on the roof of the home. The collectors must lay flat on the surface of the roof and may not include any reflective/silver surfaces. An architectural application must be made for the installation and a final inspection must be completed after installation.

Solariums are defined as a glass enclosed room attached to a house. A solarium is not permitted as an addition to an existing dwelling when the proposed solarium is larger than 12’ x 15’ subject to City of Alameda zoning ordinances and building guidelines of Bay Isle Pointe and the Community Architectural Committee. Solariums are not permitted in front yards. Reflective or mirrored glass is not permitted. Solariums are not to be considered for use as bedrooms.

Solariums constructed predominantly of pre-manufactured metal and glass components, such as aluminum window sash with glass and metal fill-in panels, are specifically prohibited since their overall appearance is not harmonious with the architectural character of homes in Bay Isle Pointe.

IMPORTANT All applications for a solarium addition must include the following:

1. The location and size of the solarium in relation to the house, fence and lot lines, drawn to scale.
2. Legible Manufacturer Cut Sheets of the solarium to be used, including design, dimensions, materials and details, including the window(s) and doors to be used therein.

Utility Boxes (including but not limited to gas and water meters, cable and telephone boxes, utility panels, etc.) shall be installed so as to not be visible from public ways, where possible, and shall be painted with the same house paint color and sheen to match the surface to which they are attached or to which they are immediately adjacent.

Windows Approved window colors are bronze (or the approved equivalent thereof), almond and white Replacement windows of a different style or design other than original windows will be reviewed for compatibility in style and design with the existing or proposed windows as well as compatibility with the existing house design. Casement windows or awning windows are not allowed on the street side of a home. Any and all windows that are visible from a public area must match in color and materials (i.e. cannot replace only the front windows if side & rear windows are publicly visible, etc.).

Windows are to be installed flush or recessed within the existing window trim. No protrusion of any part of the installed window beyond the profile of or onto the existing trim is allowed, and window trim depth, width and length is not to be altered from the original installed size. (**See Exhibit “B” – Proper Window**

Replacement Installation Details). Faded window colors are to be restored to the original colors. If windows are wood, the exterior of the window must be painted to match one of the approved colors for windows and a paint color sample is to be submitted for approval (anodized bronze, almond or white colors).

IMPORTANT All applications for window replacement must include the following:

1. The location of the windows on the home which are to be replaced and type of operation for each location (include a diagram of the home if possible).
2. A sample of the color proposed.
3. Legible Manufacturer Cut Sheets of the window(s) to be used, as well as design, dimensions, materials and details of window(s) to be used.

Wires, Lines, or Conduits that are visible from public ways or neighboring property are prohibited. Cable lines, conduits or telephone lines shall be installed in an unobtrusive and, to the extent possible, a compatible, shielded manner (i.e. running under siding, shingles, etc., where possible). Any exposed wiring, lines or conduit must be painted to match the color of the house, roof or trim to which it is adjacent).

OUTDOOR YARD STRUCTURES

All proposed outdoor structures require the submission and approval of an architectural application and plans **prior** to the commencement of property improvement work.

Animal shelters shall be constructed of materials and colors matching the house or of natural wood. Wire mesh windows, fiberglass or plastic materials are prohibited, except for small bird houses. Shelters shall be at least 6 inches lower than the fence. Shelters shall not be attached to fences and must be located to avoid noise, odor and other nuisances to neighbors. Shelters must meet the 6 inch clearances and maintenance rule.

Arbors, gazebos and overhead trellises shall be constructed of appropriate outdoor wood material which shall be left in its natural state or sealed with a clear non-gloss sealer. Redwood stain or paint is prohibited for free-standing structures. Arbors and overhead trellises attached to the house may be painted a color matching the house siding or trim. Structures must be set back from the fence as determined on a case-by-case basis, depending on the proximity of neighboring houses, a minimum of 6 inches. Structure height over the acceptable standard of 8 feet 6 inches over the grade shall be similarly determined.

For purposes of distinction herein the definitions for arbor, gazebo and overhead trellis are as follows:

- (1) An arbor is an overhead latticework structure.**
- (2) A gazebo is a freestanding roofed structure open fully or partially on the sides.**
- (3) A trellis is a framework of open latticework used as a screen or as a support for plants.**

Barbecues or Fire Pits (including chimneys) for permanent installation must be lower than the fence height and must be located in an area that will not permit smoke to unreasonably intrude into neighboring property.

Benches (permanent) shall be constructed of redwood, Ipe wood, earth tone brick, concrete or stone and shall be left natural or treated with clear non-gloss sealer. On a case-by-case basis, wood benches may be approved for painting to match the house paint colors.

Clothes Drying Facilities Outdoor clotheslines/drying structures are not permitted.

Decks Shall be constructed of Redwood or Western Red Cedar or Ipe Wood and shall be left in their natural state or sealed with a clear non-gloss sealer. Decks may be stained with Olympic Maximum Wood Toner in the following colors: Redwood (704), Cedar Naturaltone (716) Redwood Naturaltone (717) Ground level decks shall be a maximum of 12 inches from the grade and shall be no closer than 6 inches to a fence. **Lagoon Lot Decks and Patios**, see "Hardscape" on Page 15.

Trex, in Winchester Gray, may used as an alternate deck building material as long as it is not mixed with any other noticeable building material. e. g., railings, trim members, fascias must also be Trex.

For purposes of distinction herein the definition for deck(s) is a flat floored roofless area adjoining a house.

Docks must be built in compliance with the Community of Harbor Bay Isle Private Dock Guidelines including the Maximum Building Envelope for Lagoon Decks. Docks shall be constructed of Redwood, Ipe wood or Western Red Cedar and shall be left in their natural state or sealed with a clear non-gloss sealer. Dock decking material must be constructed of Redwood, Western Cedar or Ipe wood. Ipe wood may be used as long as it is not mixed with any other building materials e.g. railings, trim members etc." Docks may be stained with Olympic Maximum Wood Toner in the following colors: Redwood (704), Cedar Naturaltone (716) Redwood Naturaltone (717)

Trex Deck in the color of Winchester Gray is permitted as an additional decking material on docks only, with the fascia board around the dock remaining Redwood or Western Red Cedar. Pressure treated wood is not permitted. Private docks must be maintained in a condition meeting the standards of the Association. Light installations on docks are prohibited. Dock use shall be limited to the launching and enjoyment of up to 2 small non-motorized boats. Barbecues, garbage containers, sports and other recreational equipment, plants, furniture and other objects on private docks are prohibited.

Driveways, Interlocking Pavers Replacement may be like for like or square or rectangular interlocking concrete pavers (90 degree angled corners) may be used to replace existing driveway material. Pavers must be set with approved metal restraint system. The approved colors for the pavers are:

Single Color:	charcoal or grey
Blended Colors:	charcoal/grey

Colored coating or painting of driveways is prohibited. Excessive oil stains must be removed.

Fences The wrought iron fences along the Lagoon path and on Lagoon lots are to be painted with ***Pittsburgh Paints Pitt-Tech DTM 90-444 Satin Bronze Tone***, or equivalent. The iron handrail at the entry of some home models shall be painted to match the original coating color. Lagoon view lots which have redwood or western cedar fences may, on a case by case basis, replace the wood fences with wrought iron fences not to exceed 42 inches from ground and must be painted with ***Pittsburgh Paints Pitt-Tech DTM 90-444 Satin Bronze Tone***, or equivalent.

Fence/gate replacement (separated Fence/Gate from Fence Replacement)

Fences and gates are to be constructed of either Redwood or Western Red Cedar. Fence posts must be the same material as the fence (either Redwood or Western Red Cedar). Pressure treated posts are permitted. Fences may not be painted or stained, but must be allowed to weather naturally or be sealed with a clear non-gloss sealer. Fences and gates must match the original installation as to materials, style, design, location and size. Gates, on a case by case basis, may be modified from the original developer installed model. They must be constructed of redwood or western cedar and may not be painted and may not have any glass.

Fence extensions on original installed Bay Isle Pointe fences (short and tall), (not Community Fences) must meet the Fence Extension Detail Sheet requirements attached hereto as Exhibit "F". Fence extensions must be constructed of either Redwood or Western Red Cedar. Fence posts must be the same material as the fence (either Redwood or Western Red Cedar). Pressure treated posts are permitted. Fence extensions will be considered on a case by

case basis taking into consideration site grade changes, neighbor privacy issues and overall aesthetic effect on the area concerned. All **Community fence extensions** must comply with the Community of Harbor Bay Isle Standard Details for Community Fence Extensions. Fences and approved extensions may not be painted or stained, but must be allowed to weather naturally or be sealed with a clear non-gloss sealer. Extensions to Community maintained perimeter fences may not be sealed. Fences must match the original installation as to location, design and size, not the fence depicted in the Community of Harbor Bay Isle's Fence Extension Detail Sheet. The Community of Harbor Bay Isle's Fence Extension Detail Sheet and material specification shall only apply to fence extensions within Bay Isle Pointe that are located on Community fences.

Firewood storage is permitted in rear and rear side yards (behind side fence) only and shall be stacked in an orderly manner. Firewood shall not come in contact with fences or houses and shall be kept out of neighboring views as much as possible.

Flagpoles and Flags Flags may be wall mounted. Flags should be maintained in an appropriate condition. United States House of Representatives HR-42 prohibits restrictions on displaying the American flag. Single, vertical flag pole installations may be permitted on a case by case basis.

Furniture used in conjunction with the landscape/hardscape of a residence shall be designed specifically for exterior gardens and patios. The color and style of these exterior furnishings shall harmonize to coordinate with the appearance and finish of the residence.

Garbage and recycling containers may be left at the street curb **only** on the evening prior to, and on the day of scheduled pickup. At all other times, containers must be stored out of sight either inside the garage or in the rear side yard (behind side fence). Garbage containers must be covered at all times to avoid odor and loose trash.

Insect traps (electronic) shall not create a nuisance to neighboring properties.

Lights on structures are permitted only if they are shielded and do not intrude into neighboring property. Bright emergency type flood lights are not permitted unless they are shielded from public view. Colored light bulbs are prohibited except during the holiday season as specified under Building Modifications. Light installations on docks are prohibited.

Light fixtures attached to the exterior of the house shall match the original installation as to size, design, materials and finish. However, alternate fixtures may be approved on a case by case basis provided they are compatible with the design and style of the house.

Mailboxes shall match the original installation, being “rural” type with round top, or may be replaced with the Pinnacle Standard Size Locking Mailbox in the color of Black. Visible brackets may not be used to attach the mailbox to the mailbox post. Newspaper tubes are not permitted. Mailboxes shall be maintained as necessary to maintain an attractive appearance, e. g. solid black paint, no dents, and doors that stay closed, etc.

Mailbox Posts shall match the original installation as to location, materials, size, style and design. If concrete footing requires replacement, the old concrete footing is to be removed to allow for the new footing in the same location unless on private property. Post may be connected to the concrete footing using Simpson Strong Tie Bracket Model #CBSQ46, or equivalent, constructed and installed pursuant to the **Mailbox Post Construction Detail Sheet attached hereto as Exhibit “C”**. Said Bracket is to be painted with Rustoleum Flat Black paint.

Patio size shall be in reasonable proportion to the landscaped yard area. Acceptable surfaces are brushed neutral or earth-tone concrete, stamped concrete in an acceptable pattern and earth-tone color, aggregate concrete mix that is earth-tone, brick, flagstone, slate, or other acceptable earth-tone stone materials reviewed on a case by case basis. Paint or colored coatings are prohibited except for a clear sealer.

For purposes of distinction herein the definition for patio(s) is a recreation area that adjoins a dwelling that is often paved (i.e. concrete, stone, etc.)

Sheds shall be constructed of materials (wood) and colors matching the house, or shall be left natural, except for a clear sealer. Shed roof material shall match that of the house roof material. Redwood paint or stain is prohibited. Shed construction, including windows or roofs, with metal, fiberglass, or plastic is prohibited. However, polypropylene sheds in an earth tone color may be allowed on a case by case basis. Sheds may not be higher than the fence unless, on a case-by-case basis, a shed roof line matching the house roof line creates a more compatible appearance and does not interfere with the neighbor’s view. Sheds must be set back from the fence at least 6 inches.

Signs For Sale or For Rent signs are permitted to be installed in windows or in the ground on private property. These signs shall be a maximum of 18” x 24”, displaying the words “for rent” or “for sale” with the agent’s name and telephone number. A maximum of one sign per home may be displayed, except for lagoon lots which may display a second sign on the lagoon side. Political signs are permitted but must be removed within 5 days following the election date. Posting signs in Association common areas is prohibited. Contractor signs (to include but not limited to remodeling, painting, roof construction) are not permitted.

Spas and saunas must be set back from the fence as determined by the Architectural Committee on a case-by-case basis depending on the proximity of

neighboring houses, however, at all times not less than 6 inches from the fence. The operating equipment must be contained in a structure not visible to neighboring property, accessible only from your lot, and the sound shall not unduly intrude into neighboring property. Spas shall drain only into the sanitary sewer system.

Speaker system amplified outdoor installations are not permitted.

Sports apparatus permanent installations, which may be viewed at ground level above the fence are not permitted. All such structures are not permitted in front yards. Also refer to Basketball Standards on page 3 of the Building Modifications.

Trellises not attached to the house, may not be higher than the top of the fence, nor attached thereto, and must be a minimum of six inches from the fence. Trellises shall be constructed of natural redwood or western red cedar, which may be treated with a clear non-gloss sealer. Vines or other plants may not be attached to shared fences.

For purposes of distinction herein the definition for trellis is a framework of open latticework used as a screen or as a support for plants.

Vehicle Storage Residents are encouraged to park their vehicles within their garage. When not parked in a garage, vehicles on a lot may only be parked on the driveway area in front of the house. At no time is a vehicle to be stored for a period of time exceeding 30 days on the driveway of a house. In addition, at no time is a vehicle(s) to be stored or parked on any other portion of the lot.

Walkway materials are limited to brushed concrete, exposed aggregate finish or interlocking pavers compatible with the house and overall neighborhood design. On a case-by-case basis, other surfaces will be considered by the Architectural Committee. Painted surfaces or colored coatings are prohibited, except for a clear sealer. Non-plant material borders must be compatible with the existing house and overall neighborhood design.

Weather vanes will be considered on a case-by-case basis.

Wind chimes are discouraged, but are permitted only if the sound level does not intrude into neighboring property.

Wrought Iron Fences The wrought iron fences along the Lagoon path and on Lagoon lots are to be painted with ***Pittsburgh Paints Pitt-Tech DTM 90-444 Satin Bronze Tone***, or equivalent. The iron handrail at the entry of some home models shall be painted to match the original coating color.

LANDSCAPE GUIDELINES

Prior approval required No landscaping may be installed nor may any existing landscaping be modified without the prior approval of the Architectural Committee. An architectural application and plans must be submitted and approved **prior** to commencing landscape installations. Owners should also review the Community's Landscape Guidelines for the specific requirements that apply to proposed property improvements. The Community Association created these more specific Guidelines for use by Bay Isle Pointe homeowners.

Bark – Mulch Bark/Mulch is a protective covering of organic material laid over the soil around plants to prevent erosion, retain moisture, and sometimes enrich the soil. Mulching shall be of organic (untreated), natural material, such as tree bark, chipped tree components, pre-decomposed plant material, or stone. Mulch shall be an aesthetic component of the general landscape design and shall not detract from the surrounding ambiance. Synthetic colors and materials are not allowed.

Bark/mulch which is artificially colored is not allowed in gardens. Bark/mulch must be non-stained, non dyed natural material. Bark/mulch color must be natural bark color.

Drainage must be appropriately maintained to avoid impacting on neighboring property, including common areas.

Drought resistant landscape material information is available from the Community Architectural Administrator.

Groundcover installations shall be in a reasonable proportion to other plantings. Artificial turf of any kind is not permitted. To preserve a greenbelt directly on the street, live ground cover shall be maintained from one-third to one-half the width of the front yard to the street.

Hardscape (patios, decks, or other structures of non-live materials) shall be proportionate to the total rear yard area. No less than 60% of the front yard area and no less than 20% of the rear yard area shall be landscaped with plant material as per the CAC Architectural Rules and Standards.

Lagoon lots shall comply with the **Maximum Building Envelope for Lagoon Decks and Patios attached hereto as Exhibit "D"**. This rule is to provide soft buffer zones between lots and minimize the appearance of "Hardscape run-on". The "envelope requirement" shall not apply to any Lagoon Lot rear yard in which the deck was originally approved prior to December 4, 1989, and meeting the 20% softscape requirements.

Current decks, patio surfaces, and retaining walls may be replaced “in-kind” providing the rear yard is in compliance with the 20% softscape requirements, originally approved prior to December 4, 1989, and the current approved materials are utilized. New installation or redesign of current decks, patio surfaces, and retaining walls must meet the requirements contained in **Exhibit “D”**.

Existing grade of lot may be considered relative to maximum height of deck or patio. The area beneath the deck shall be landscaped with a ground cover to enhance the softscape appearance, and to deter soil erosion into the Lagoon.

Lighting for accenting rear yard landscape is permitted if they are low-voltage (12V), are non-glare, low level and shielded. Only clear glass not colored lights, are permitted. Accent lights must not intrude into neighboring property. Limited front yard, low level, low voltage lights are permitted, but must be compatible with the overall neighborhood appearance. Mercury vapor, fluorescent, or quartz lights are prohibited. Light installations on docks are not permitted.

Maintenance Owners shall maintain their landscape in good condition, removing weeds, watering, fertilizing and trimming as necessary to maintain an attractive appearance. Lawns shall not exceed more than 5 inches in height (and shall be edged at the sidewalk, driveway and/or curb so as not to grow over these areas).

Planter boxes or flower pots shall be compatible with the house and overall neighborhood design.

Rock gardens in front yards are discouraged, but will be considered on a case-by-case basis if they contain an acceptable balance of rock and live plant material, and are compatible with the overall neighborhood design. Rock is to be earth tone in color. White rock is prohibited. Rock gardens shall be in compliance with the provisions set forth in the section “Hardscape” on Page 15 herein. Information about drought-tolerant landscape materials is available from the Community Architectural Administrator.

Tree installation requires prior approval of the species and planting location. Fruit-bearing trees are permitted only in back yards. Replacement of problem trees will be considered on a case-by-case basis, provided a replacement tree, or shrub is approved by the Architectural Committee. Replacement trees shall be a minimum 15 gal., or 24” box with a minimum height of 8’, a minimum breadth of 3’, and minimum caliper of 1.75”. Tree and shrub installations shall not unduly interfere with neighboring property yards or views. Trees shall be maintained in a healthy condition. If a tree’s disease becomes untreatable, or if it dies, the owner should promptly apply to the Architectural Committee for removal, and/or replacement of the tree.

Vegetable gardens are permitted only in rear yards and in reasonable proportion to other landscape.

INDEX

A

Additions, Room, 8
Additions – Ground Level, 8
Additions - Second Story, 8
Additions – Third Story, 8
Address Numbers, 2
Air Conditioners, 2
Antennas, 2
Animal Shelters, 10
Arbors, 10,11
Architectural Modifications, 1-2
Attic Ventilation, 2
Awnings, 2

B

Balconies, 8
Bark, 16
Basketball Standards/Hoops, 3
Barbecues, 11
Benches, 11
Building Modifications, 2-10

C

CC&R Compliance, 1
Chimes (wind), 15
Chimneys, 3
Clotheslines, 11
Clothes Drying Facilities, 11
Community Architectural Review, 1
Conduit, 10
Containers (recycling)13

D

Decks, 11
Docks, 11-12
Door (entry), 3,5
Door (garage), 3
Downspouts, 3-4
Drainage, 16
Driveways, 12
Drought Resistant Landscape,16

E

Entry Door, 3,5
Exterior Shades, 2
Exterior Painting, 4-6
Extensions (fence), 12
Extensions (room), 8
Exterior Painting (also check individual exterior items), 4-6

F

Fences, 12
Fence Extensions, 12
Fence Gate Replacement, 12
Fire Pits, 11
Firewood, 13
Flagpoles, 13
Flags, 13
Flower Pots, 17
Fruit Trees, 17
Furniture (yard), 13

G

Garages (vehicle storage), 3, 15
Garage Doors, 3
Garbage, 13
Gardens (rock), 17
Gardens (vegetable), 17
Gates, 12
Gazebos, 10-11
Groundcover, 16
Gutters, 3-4,7

H

Hardscape, 16
Hot Tubs (spas), 13

I

Insect Traps, 13
Interlocking Pavers, 12

L

- Lagoon Lot Decks & Patios, 11,14
- Landscape, 16-17
 - Drought Resistant, 16
 - Guidelines, 16-17
 - Hardscape Requirements, 15-16
 - Softscape Requirements, 16
 - Standards/Guidelines, 1
- Lights
 - Landscape, 13-17
 - Outdoor, 4,13
 - Seasonal, 4,13
- Lines
 - Cable, 10
 - Utility, 10

M

- Mailbox Posts, 14
- Mailboxes, 14
- Maintenance-landscaping, 17
- Metal Flues, 3
- Motion Detectors, 8
- Mulch, 16

O

- Outdoor Lights, 4,13
- Overhead Trellis, 10

P

- Paint, 4-6
 - Alarm Boxes, 5
 - Animal Shelters, 10
 - Arbors, 10
 - Chimneys, 3
 - Conduit, 10
 - Decks & Docks, 11
 - Downspouts, 5
 - Entry Doors, 3,5
 - Exterior Guidelines, 4-6
 - French Doors, 5
 - Garage Doors, 5
 - Gazebos, 8
 - Gutters, 4
 - Handrails, 6
 - Lines, 10

P-(continued)

- Paint (continued)
 - Metal Flues, 2, 5
 - Palette, 4-5
 - Roof Metal Flashing, 5
 - Roof Penetrations, 5
 - Sheds, 13
 - Stove Pipes, 5
 - Trellises, 9
 - Utility Boxes, 9
 - Vents, 2, 17
 - Wires, 8
 - Wrought Iron Fences, 5
- Patios, 14
- Planter Boxes, 17
- Porches, 6

R

- Recycling Containers, 13
- Rock Gardens, 17
- Room Additions, 8
- Room Extensions, 8
- Roofs, 6-7

S

- Satellite Dishes, 2
- Saunas, 14-15
- Security Lights, 13
- Security System, 8
- Shades, exterior, 2
- Sheds, 14
- Siding Materials, 8
- Signs, 14
- Skylights, 8
- Solar Collectors, 8
- Solariums, 9
- Spas (hot tubs), 14-15
- Speaker Systems, 15
- Sports Apparatus, 15
- Softscape, 16
- Stove Pipes, 3,5
- Sun Shields, 2

T

Trees, 17

Trellises, 5,11

Trim Painting, 5-6

U

Utility Boxes, 9

V

Vegetable Gardens, 17

Vehicle Storage, 15

W

Walkways, 15

Weather Vanes, 15

Wind Chimes, 15

Windows, 9-10

Wires, 10

Wrought Iron Fences, 15

Exhibit "A"
Roof Rake Installation Method

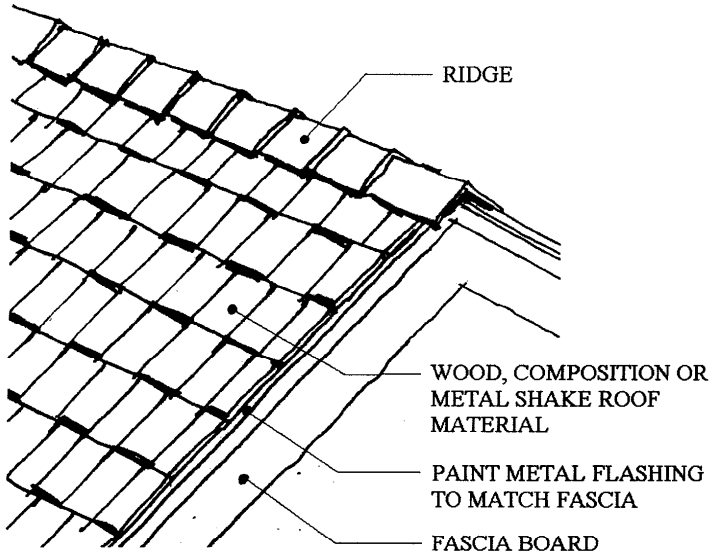

ACCEPTABLE METHOD

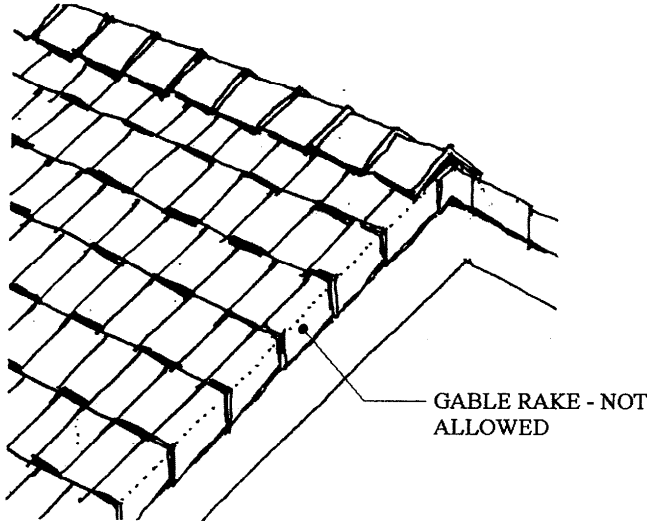

UNACCEPTABLE METHOD

ROOF RAKE INSTALLATION METHOD

Exhibit "B"

Proper Window Replacement Installation Details

BAY ISLE POINTE ASSOCIATION WINDOW REPLACEMENT SPECIFICATIONS - 4/30/02

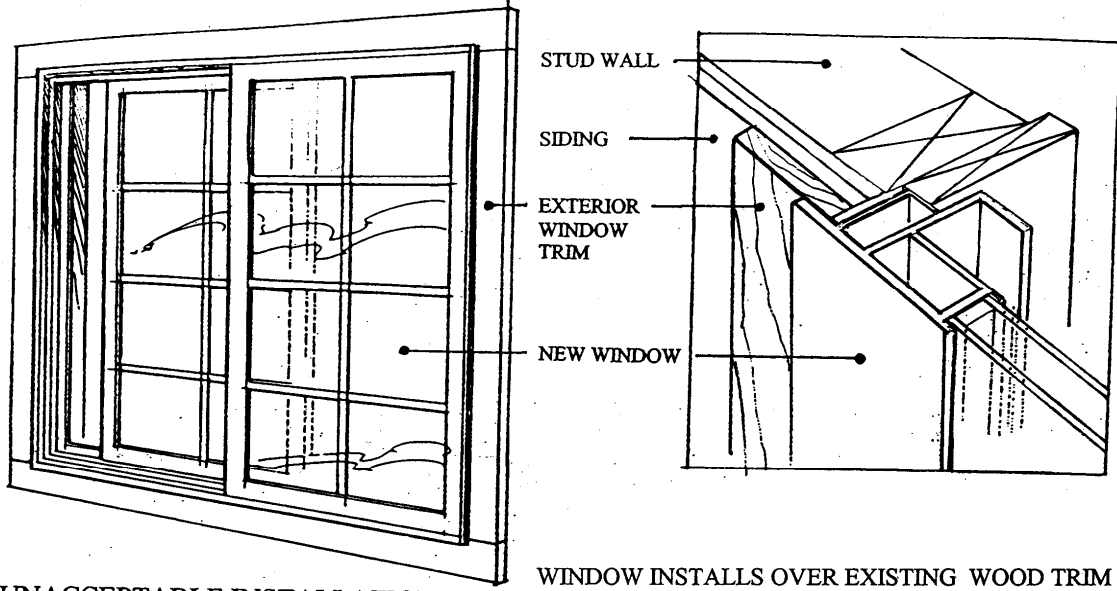

UNACCEPTABLE INSTALLATION

WINDOW INSTALLS OVER EXISTING WOOD TRIM
WINDOW EXTENDS BEYOND WINDOW TRIM

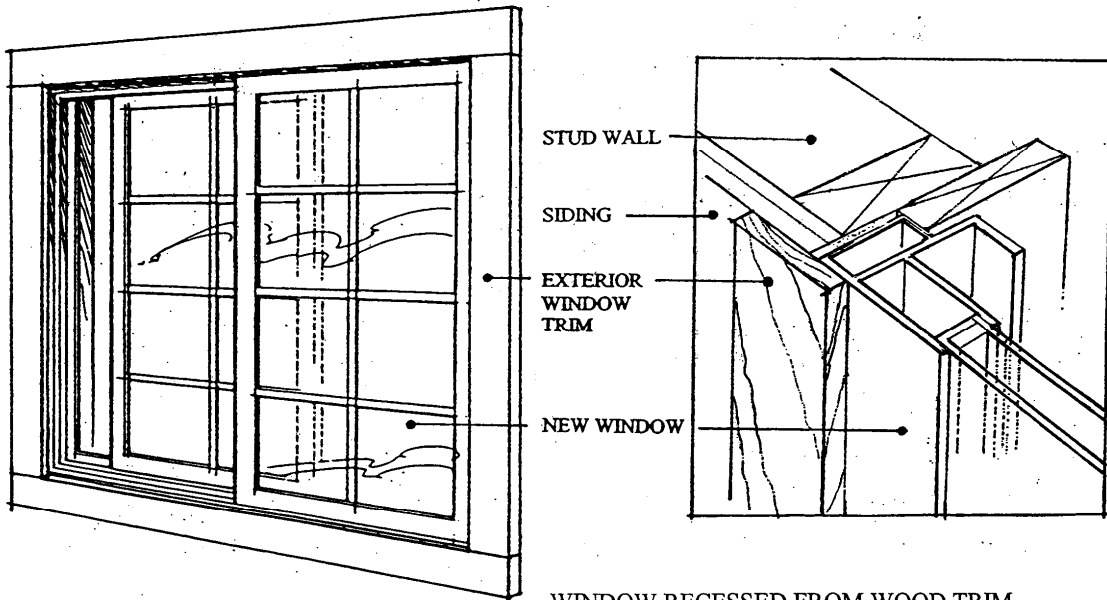

ACCEPTABLE INSTALLATION

WINDOW RECESSED FROM WOOD TRIM
WINDOW FLUSH WITH WOOD TRIM

PROPER WINDOW REPLACEMENT INSTALLATION DETAILS

Exhibit "C"

Mailbox Post Construction Detail Sheet

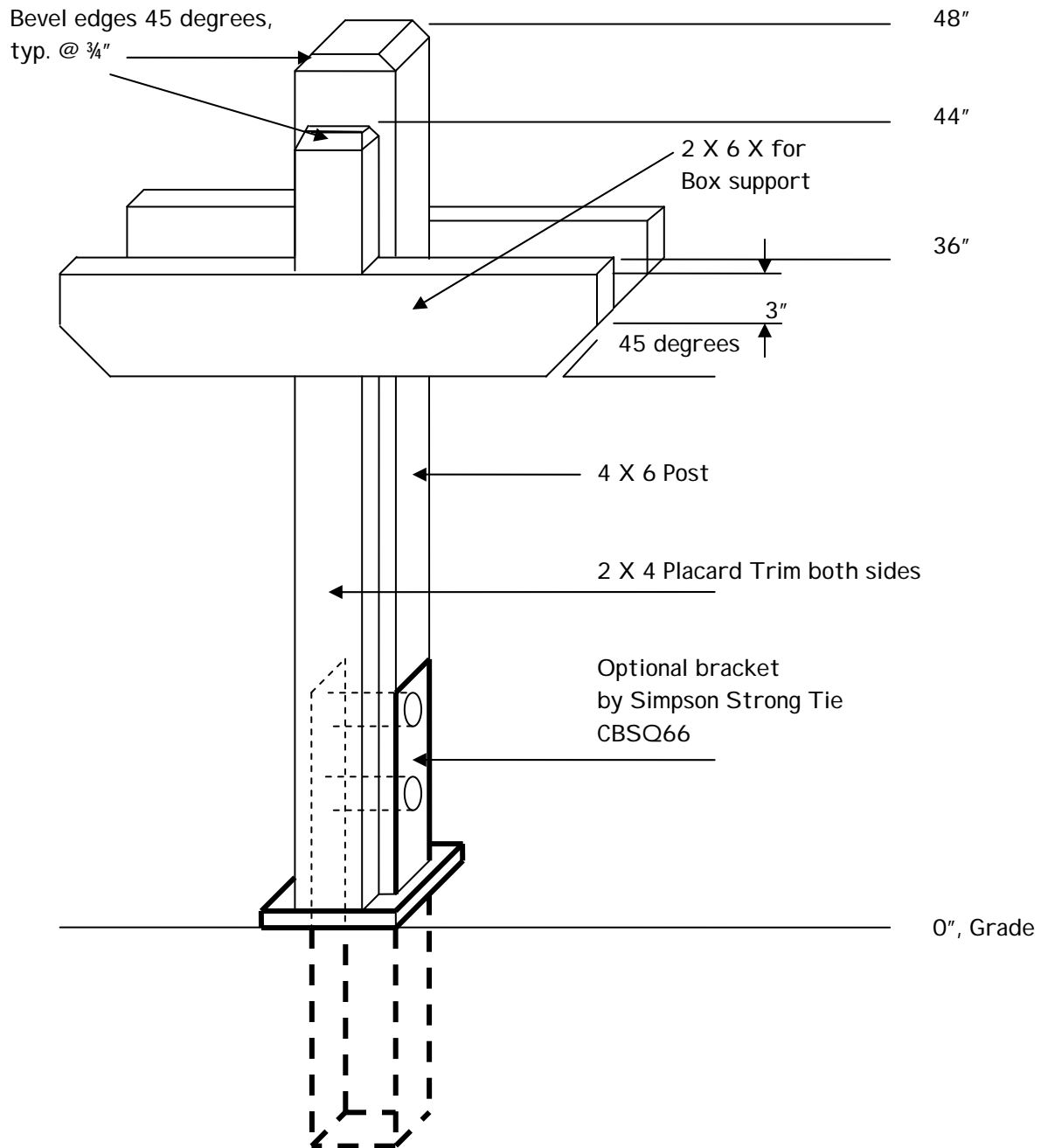

Material to be rough, Redwood.
Fasteners to be Hot Dipped Galvanized
Optional Bracket to be painted
Rustoleum, Flat Black

Bay Isle Pointe HOA
Mail Box Post Specifications
Architectural Guidelines, 2005

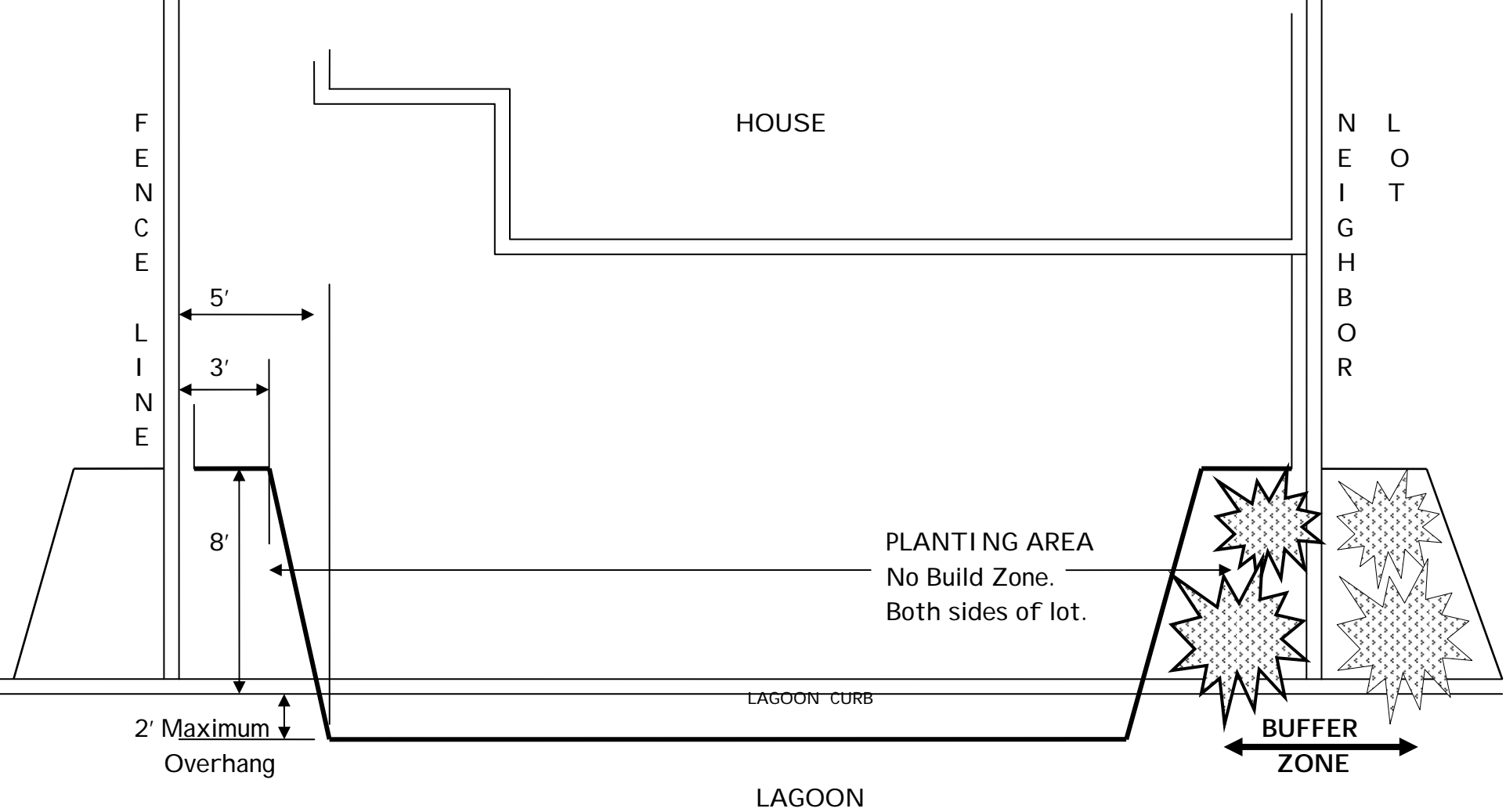

Note: Existing grade of lot may be considered relative to maximum height of deck or patio

Bay Isle Pointe Homeowners Association
 Patio and Deck Building Envelope
 For Lagoon lots
 Architectural Guidelines, 2005

Exhibit D

EXHIBIT "E" House Painting Detail Sheet

NO CHANGES PERMITTED UNLESS APPROVED. No changes shall be made in the color scheme after it has been approved unless the proposed changes are resubmitted to the Community Architectural committee and are approved. *If you hire a contractor to paint your home, please provide the contractor with a copy of your application approval letter and a copy of the attached house repainting rules.*

PAINT GLOSS CATEGORIES: Exterior paints are comprised of 5 gloss categories. The following exterior paint finishes are permitted under each category:

<u>Flat</u>	<u>Low sheen</u>	<u>Satin</u>	<u>Eggshell</u>	<u>Semi-gloss</u>	<u>Gloss</u>
Siding	Siding Trim	Siding Trim Accent Front door*	Trim Accent Front door*	Front door**	<u>NO</u> Exterior Use

* Refer to your Project Association's House Repaint Rules to learn if painting front doors is permitted in your association.

** When painted front doors are permitted by a project association, *if specifically requested on your architectural application*, semi-gloss paint will be considered on a case-by-case basis.

SAMPLE ARCHITECTURAL AREAS OF A HOUSE. The following house design may not match your house's architectural details, but will identify the different areas of the house exterior details for painting.

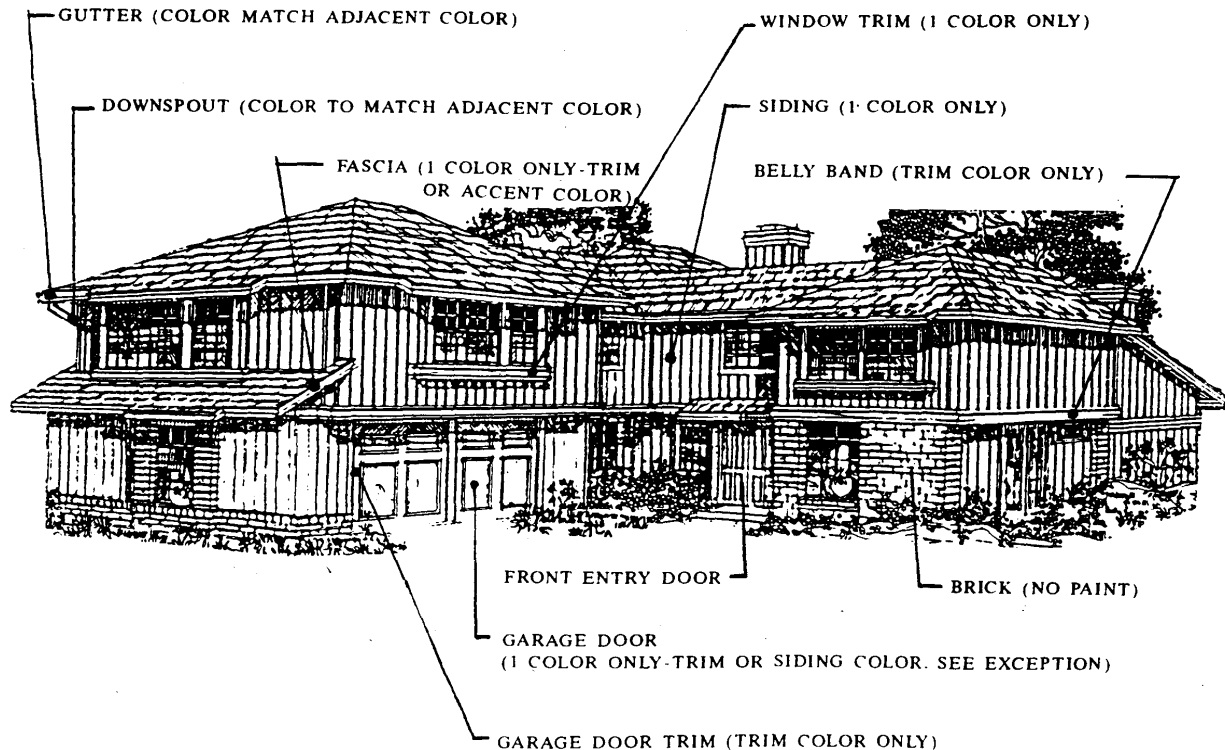

EXHIBIT "F"
Fence Extension Detail Sheet

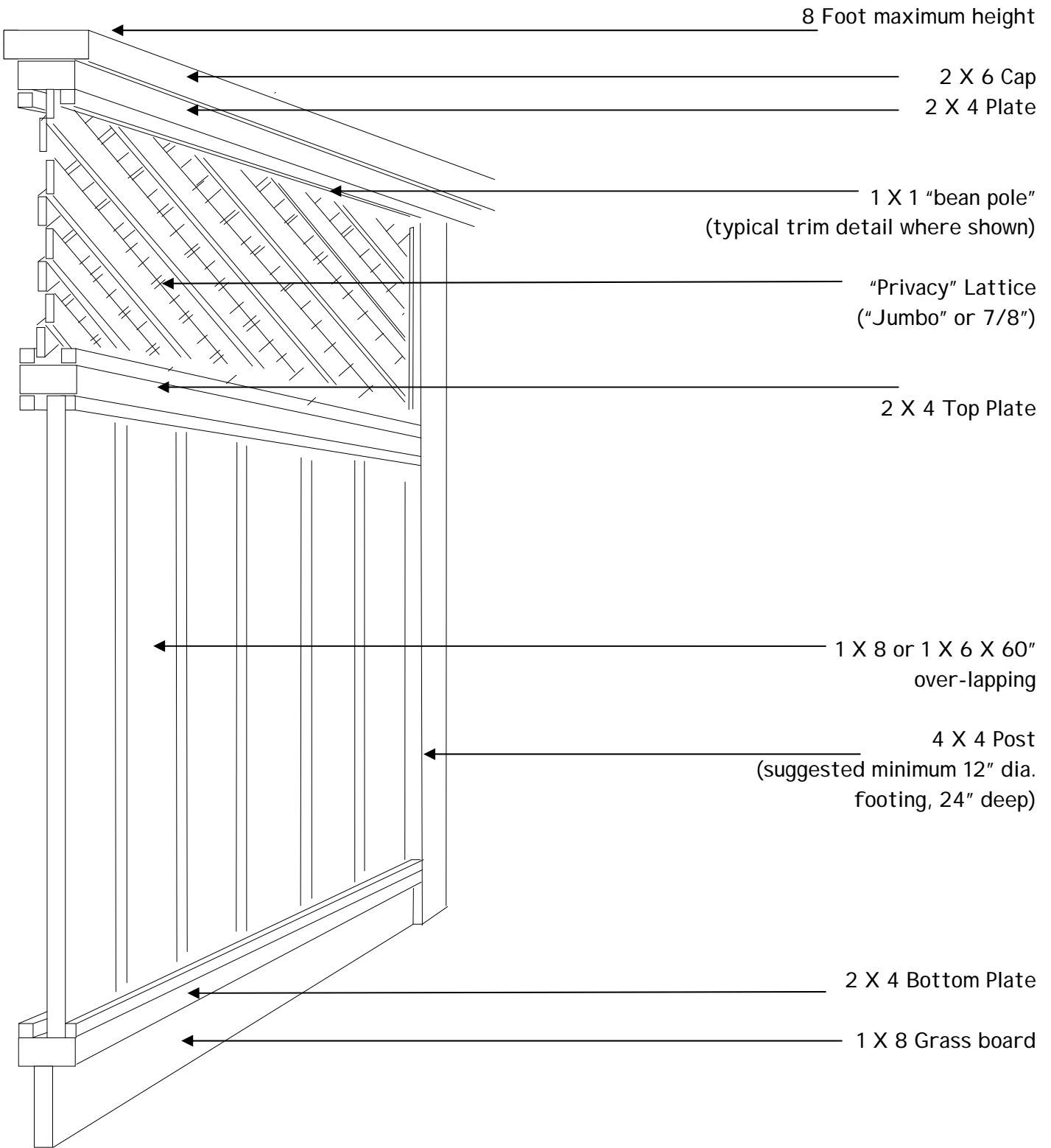
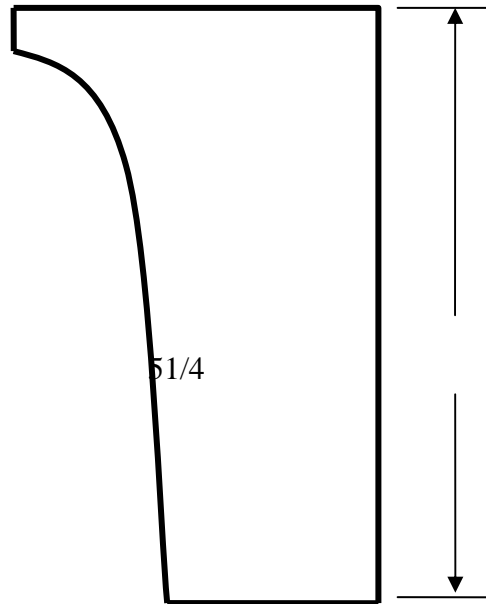

EXHIBIT G

Bay Isle Pointe HOA Approved Gutter Profiles

2 X 4 X 5/4"
Curved fascia gutter



2 X 4 X 5/4"
1, 2, or 3 groove
fascia gutter

